

## REMOVAL AND INSTALLATION

### Front Seat

NOTE: Driver seat shown, passenger seat similar.

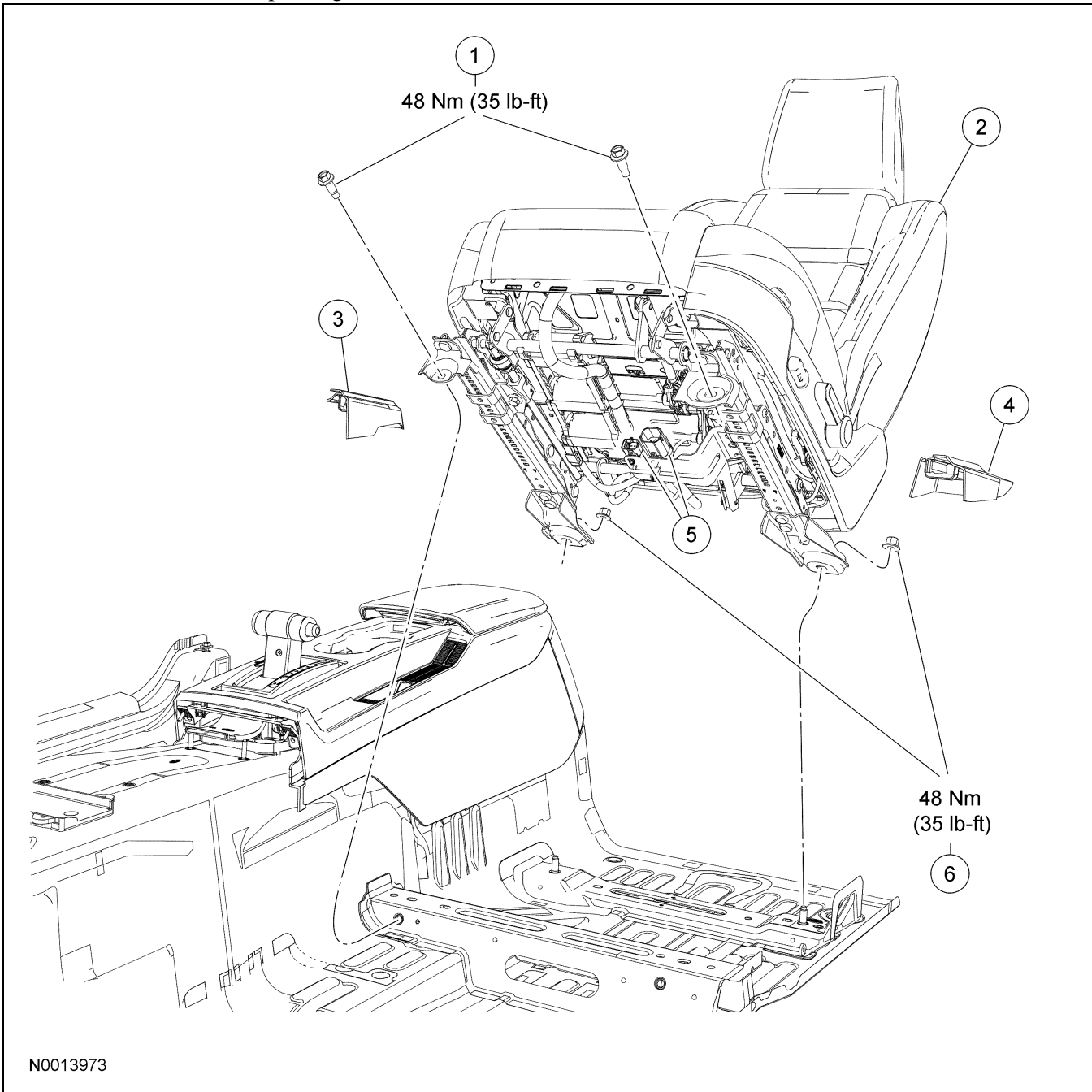

N0013973

| Item | Part Number | Description                  |
|------|-------------|------------------------------|
| 1    | —           | Seat track-to-floor bolts    |
| 2    | —           | Front seat                   |
| 3    | 618C84      | Inboard seat track nut cover |

(Continued)

| Item | Part Number  | Description                                    |
|------|--------------|--|
| 4    | 618C82       | Outboard seat track nut cover                  |
| 5    | —            | Seat electrical connectors<br>(part of 14A699) |
| 6    | N807939-S424 | Seat track-to-floor nuts                       |

## REMOVAL AND INSTALLATION (Continued)

### Removal and Installation

**⚠ WARNING:** Always wear safety glasses when repairing an air bag supplemental restraint system (SRS) vehicle and when handling an air bag module. This will reduce the risk of injury in the event of an accidental deployment.

**⚠ WARNING:** After deployment, the air bag surface can contain deposits of sodium hydroxide, a product of the gas generant combustion that is irritating to the skin. Wash your hands with soap and water afterwards.

**⚠ WARNING:** Never probe the connectors on the air bag module. Doing so can result in air bag deployment, which can result in personal injury.

**⚠ WARNING:** To reduce the risk of personal injury, do not use any memory saver devices.

**NOTE:** If a seat equipped with a supplemental restraint system (SRS) component is being serviced, the supplemental restraint system (SRS) must be depowered.

**NOTE:** The air bag warning lamp illuminates when the RCM fuse is removed and the ignition switch is ON. This is normal operation and does not indicate a supplemental restraint system (SRS) fault.

**NOTE:** The SRS must be fully operational and free of faults before releasing the vehicle to the customer.

1. Position the seat to gain access to the seat track-to-floor nuts and bolts.
2. Depower the SRS. For additional information, refer to Supplemental Restraint System (SRS) Depowering and Repowering in the General Procedures portion of Section 501-20B.
3. Release the safety belt loop magnet at the side shield and separate the safety belt from the seat.
4. Slide back and remove the 2 seat track nut covers.
5. Remove the seat track-to-floor nuts.
  - To install, tighten to 48 Nm (35 lb-ft).
6. Remove the seat track-to-floor bolts.
  - To install, tighten to 48 Nm (35 lb-ft).
7. Tip the seat, disconnect the side air bag module (if equipped) and main seat harness electrical connectors and remove the seat.
8. To install, reverse the removal procedure.
9. Repower the SRS. For additional information, refer to Supplemental Restraint System (SRS) Depowering and Repowering in the General Procedures portion of Section 501-20B.